

## DESCRIPTION AND OPERATING INSTRUCTIONS FOR THE BACK-FLUSHING FILTER TYPE 6.62

---

Commission No.

### CONTENTS

1. Type sheet
2. General Information on the Automatic Filter
3. Filter Installation
4. Commissioning
5. Filtration Phase Z40130 Sheet 1
6. Back-Flushing Position Z40130 Sheet 2
7. Description of the Electric Control System
8. Circuit Diagram
9. Equipment List for Electric Control System
10. Servicing
11. Servicing Tools
12. Cleaning Agents for the Candle Elements
13. Manual Cleaning of the Candle Elements
14. Spare Part Drawing for Type 6.62
15. Spare Part List for Type 6.62
16. Type Sheet for the Differential Pressure Indicator with Electrical Contact
15. Spare Part Drawing for the Differential Pressure Indicator

Z100826  
TYP6.62  
27.01.98

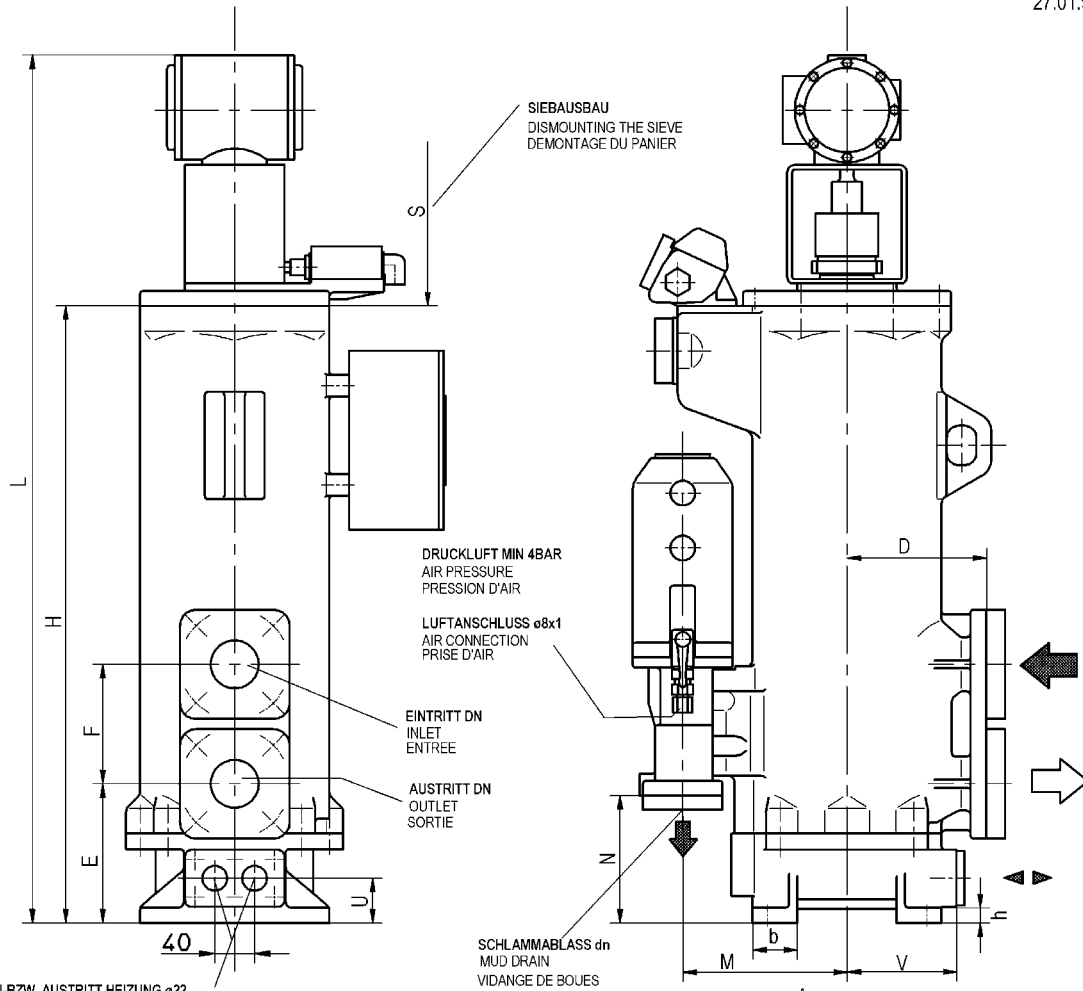

EIN-BZW. AUSTRITT HEIZUNG  $\varnothing 22$   
IN RESPECTIVELY OUTLET HEATING  $\varnothing 22$   
ENTREE RESPECT. SORTIE CHAUFFAGE  $\varnothing 22$

BETRIEBSDRUCK FILTERRAUM  
WORKING PRESS. FILTER CHAMBER  
PRESS. DE SERVICE CHAMBRE FILT. } max. 16 BAR BEI 160°C PAR

HEIZRAUM  
HEATING CHAMBER  
CHAMBRE DE CHAUFFAGE } 14 BAR BEI 200°C PAR

FREIMASSTOLERANZEN  
TOLERANCE  
TOLERANCE } DIN ISO 2768-m

GEGENFLANSCH IM LIEFERUMFANG  
COUNTER FLANGES INCLUDED  
CONTRES BRIDES INCLUS

GEHAUSE GEGOSSEN  
HOUSING IN CAST IRON  
CORPS MOULE

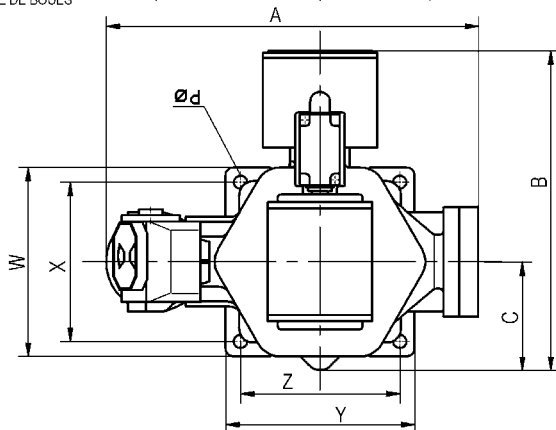

GR.	DN	A	B	C	D	E	F	H	L	M	N	S	U	V	W	X	Y	Z	b	h	d	dn	GEWICHT KG	INHALT LTR
04	40	375	325	110	140	140	120	620	875	165	130	500	45	110	190	160	190	160	45	15	13.5	25	105	14

SUBJECT TO ALTERATIONS!

AENDERUNGEN VORBEHALTEN!

MODIFICATIONS RESERVEES!

FULLY AUTOMATIC BACK  
FLUSHING FILTER

**VOLLAUTOMATISCHER RUECKSPUELFILTER**  
TYP 6.62

FILTRE AUTOMATIQUE

## 2. General

The fully automatic back-flushing filter is used to filter a wide variety of fluids, preferably fuels and lubricating oils. The candle elements are cleaned automatically by compressed-air-assisted back-flushing without causing interruptions to the filtration process. One clean candle element is always held in reserve.

This self-cleaning filter basically consists of the following parts:

- the housing with the inlet and outlet flanges
- the lower housing with integrated heating chamber (circulation heating)
- the filter element assembly with the individual chambers to accommodate the filter candles
- the pneumatic swivel drive with attached solenoid valve
- the sludge discharge valve with internal valve tappet and air receiver
- the air supply with shut-off valve, non-return valve and pressure regulator
- the flushing valve (solenoid valve) with manual initiation
- the differential pressure indicator with electrical contact
- the electric control system in its own switch box separate from the filter.

### 3. Filter Installation

Care must be taken during installation of the filter to ensure that the pipes attached to the filter inlet and outlet are clean and not under tension.

The pipe selected for the sludge discharge is to be no smaller than the size indicated in the type sheet. In order to prevent back-pressure arising in the pipe, it is to be laid on a gradient and vented.

The terminal board on the filter is to be connected to the terminal board in the switch cabinet by means of the control system cable (see terminal diagram).

**Note:** When the filter is used in aqueous media, it is imperative to observe the following:

- 3.1 It must be ensured that the filter does not run dry even after the supply pump has been switched off (owing to hardening of dirt).
- 3.2 If this condition cannot be fulfilled, at least the electric control must be set so that, even when the supply pump is switched off, back-flushing is initiated every 4 hours by a time relay.



Flushing operations into a completely empty chamber for test purposes are permitted without any restrictions. Flushing into a partially filled chamber results in increased loading of the filter candles. Back-flushing for installation (pipe) or control reasons into a filter chamber which is only partially filled is therefore inadmissible!



The filter housings are only designed for internal overpressure in accordance with the AD Information Sheets. Additional external forces and moments at the filter connection flanges are to be avoided (possibly by supporting the supply lines).



When installing the filters, make sure that any oil or fuel which leaks due to improper handling cannot result in a fire or injury.

#### 4. Commissioning

The following requirements must be met for the commissioning of the filter:

- 4.1 Clean and dry compressed air for the control system at 4 to 10 bar operating pressure must be available at the open shut-off valve.
- 4.2 Switch on the electric control using the "Main Switch" on the switch box. The "Power" lamp and LED operating display light up.  
(Activation of the main switch initiates a back-flushing cycle).
- 4.3 To check the electric control system, a back-flushing cycle should now be performed by activating the "Manual" trip on the switch box.
- 4.4 Open the slide valve at the filter outlet. Slowly open the slide valve at the filter inlet (avoiding pipe hammer). Then perform a further back-flushing cycle using the "Manual" trip on the switch box. Once the back-flushing operation is completed, the "Flushing" and the display "SP.1" lamps go off. If these conditions are met, the filter is in the start position and is therefore ready for operation.



After completion of a back-flushing cycle, the next back-flushing operation can only be initiated after a time delay (manually or by means of the differential pressure indicator). This time delay corresponds to the time preset on the time relay or the preselected time "PA.5" in the electronic control. It is needed to guarantee that the cleaned filter chamber is filled!

**Note:** *Possible time interval calculation for time-dependent back-flushing*

Let the filter run for 24 hours using the differential pressure and establish the number of back-flushing operations (flushing cycle counter or display).

Calculate the average flushing interval.

Set the flushing interval (shortened by 30%) on the time relay or PA.2.

## 5. Filtration Phase (see drawing Z40130 Sheet 1)

The medium to be filtered flows through the top inlet flange into the housing (2) and from there through the individual filter chambers to the candle elements (6). The medium flows through the candle elements (6) from the outside to the inside and the contamination in the medium is retained on the filter mesh of the candle elements (6). The cleaned fluid passes to the bottom filter outlet.

In this position the air supply (by means of the solenoid valve [122]) keeps the sludge discharge valve (valve tappet [29]) closed and compressed air is maintained in the air receiver ready for the next back-flushing cycle.

Z40130 BL.1  
TYP6.62  
15.09.97

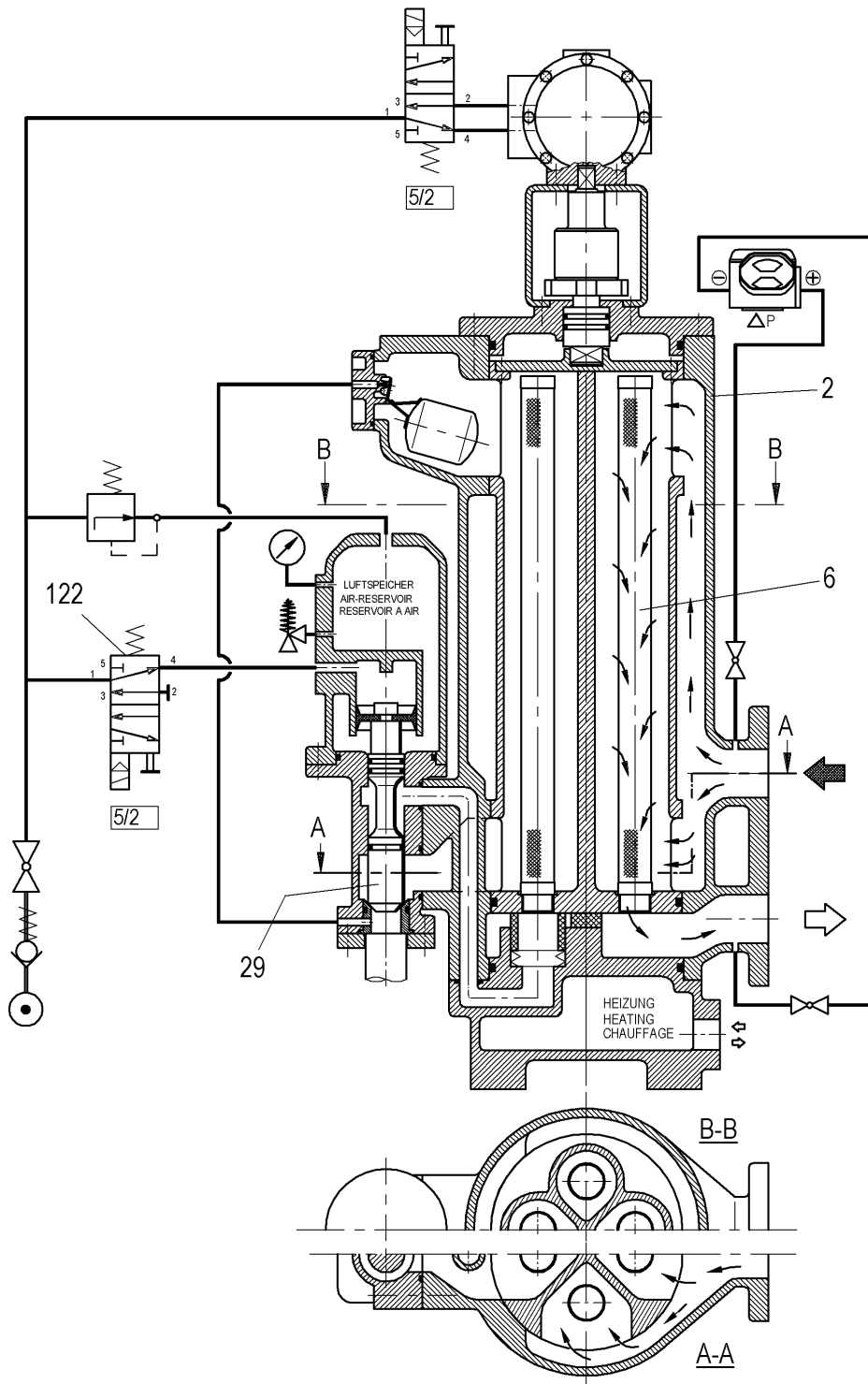

TYP 6.62	FILTRATIONS-PHASE FILTRATION-PHASE PHASE DE FILTRATION
----------	--

## 6. Back-Flushing Position (see drawing Z40130 Sheet 2)

The contamination retained on the candle elements produces an increasing pressure differential between the filter inlet and outlet. This difference in pressure is indicated optically on the differential pressure indicator when a set value is reached and an electrical contact initiates a back-flushing operation by means of the electric control.

When the back-flushing cycle is initiated, the pneumatic swivel drive is switched over by means of the attached solenoid valve. Several activations of the pneumatic swivel drive (119) cause, by means of a free-wheel, the filter element assembly (5) to turn from the clean candle element (6) held in reserve to the candle element to be cleaned.

The activation of the clean candle element results in an immediate reduction in the differential pressure. When the candle element (6) to be cleaned reaches the back-flushing position, the rotary motion is interrupted by the electric control.

The solenoid valve (122) is now switched over electrically; the upper side of the valve tappet (29) is vented. The valve tappet (29) opens the sludge discharge and the shut-off candle element is pressure-relieved.

While the valve tappet (29) is opening, the compressed air passes from the air receiver (26) (only after the pressure has been relieved in the candle element), accelerates the clean fluid in the candle element (6) and presses it in countercurrent through the candle element (6). The pressure drop thus generated flushes the contamination deposited on the candle element (6) out of the filter housing through the open sludge discharge valve.



After a brief blow-out period (flushing time) the solenoid valve (122) is electrically activated, closing the valve tappet (29). At the same time the supply of stored back-flushing air is stopped. The previously back-flushed candle element (6) is now filled by means of the refill bore until the operating pressure has been reached. Only then is the delay of the electric control cancelled for the next back-flushing operation.

Z40130 BL.2  
TYP6.62  
15.09.97

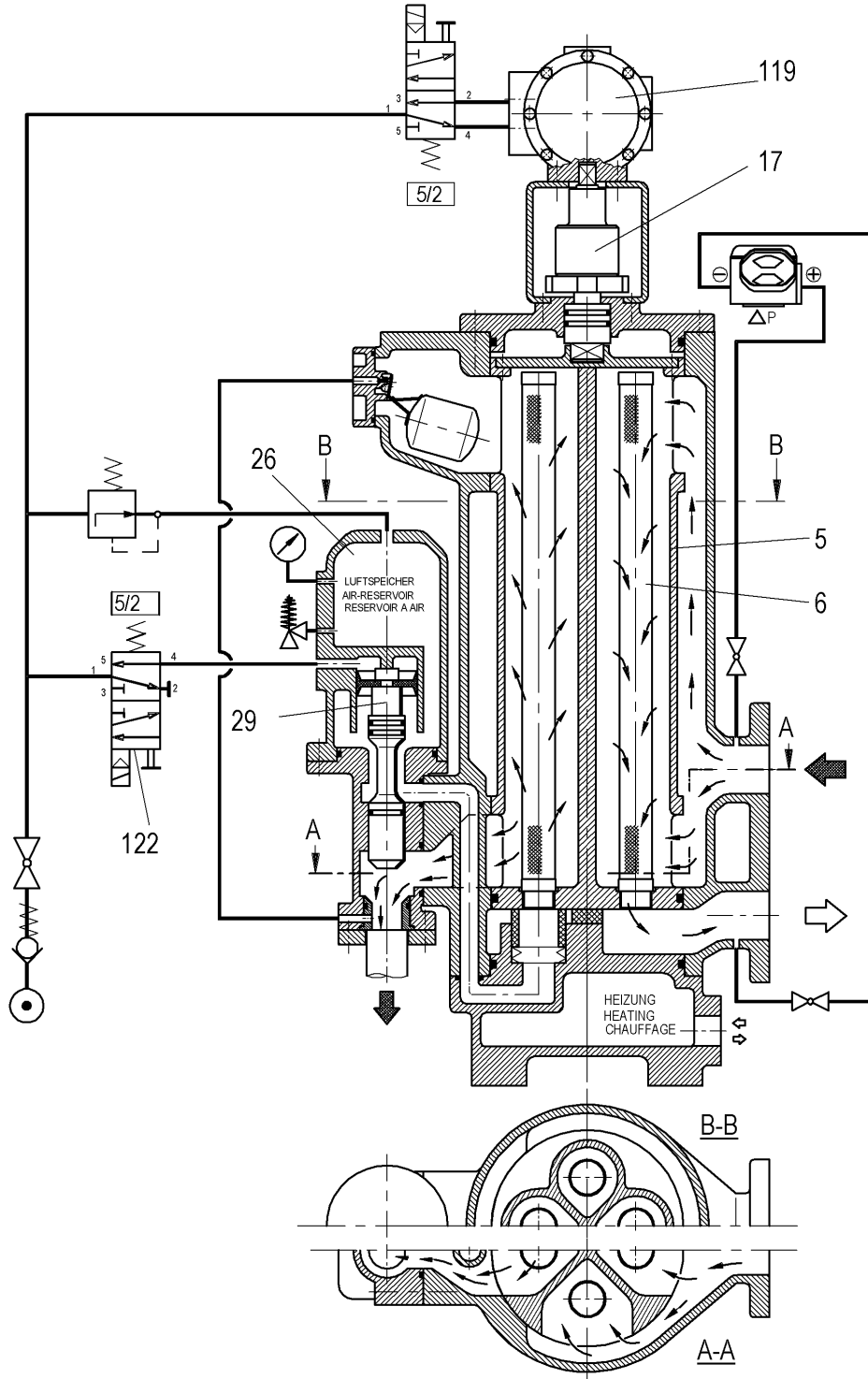

TYP 6.62	RUECKSPUELPHASE
	BACK-FLUSHING-PHASE
	POSITION DE LAVAGE A
	CONTRE-COURANT

## 10. Servicing

Even automatic filters require inspection and servicing at regular intervals.

It is to be noted in particular that despite regular back-flushing the filter mesh can become clogged over the course of time, depending on the quality of the medium and the by-pass cleaning available. Contamination on the mesh can be removed by cleaning the candle elements manually using an appropriate solvent (see Section 13). An increase in the clogging on the mesh can be inferred from progressively shorter intervals between back-flushing cycles.

The number of back-flushing cycles can be seen on the "Flushing Cycle Counter" or on the display on the switch box.

To maintain trouble-free operation, the following points are to be noted:

- a) All connections are to be regularly checked for leaks.
- b) Candle elements are to be dismantled and inspected initially after 500 flushing cycles, then after 5,000 and later every 10,000 flushing cycles. If, however, a sharp reduction in the intervals between back-flushing cycles should occur, inspection and cleaning should be carried out sooner. If the intervals between the back-flushing cycles suddenly become longer, all the candle elements must be inspected for damage without fail.
- c) Check the sludge discharge for leaks every 10,000 flushing cycles! No medium should run from the end of the sludge discharge line during the filtration phase (except during the flushing cycle).



Before the filter element assembly (5) with the candle elements (6) is dismantled, the automatic filter must be drained by automatic back-flushing. "Manual" activation on the switch box.

**Note:** The candles are subjected to wear through reciprocal loading. It is therefore recommended that a complete set of candle elements be kept in stock.



It is expedient to renew all seals when overhauling the filter.

## 11. Servicing Tools

The following special tools are supplied for servicing the filter:

- 11.1 Special key for unscrewing the candle elements from the candle holder.



- 11.2 Key for opening the switch box and hand crank for operation during a power failure.



## 12. Candle Element Cleaning Agent "BOLL CLEAN 2000"

The choice of cleaning medium depends on the type of the contamination. With fuels precipitation of paraffin and asphalt or with lubricating oils mixing of different types of oil can form solid encrustations on the mesh. Effective cleaning of fine meshes is achieved by soaking in "BOLL CLEAN 2000" followed by blasting with compressed air using a cleaning gun.

### PRODUCT DESCRIPTION:

BOLL CLEAN 2000 is a fluid cleaning and degreasing agent with a wide range of application. It can be used for practically all cleaning and degreasing purposes. BOLL CLEAN 2000 cleans rapidly, thoroughly and extremely economically. Use of BOLL CLEAN 2000 renders safety precautions superfluous. BOLL CLEAN 2000 has these outstanding characteristics without exhibiting the disadvantages of solvent cleaners.

BOLL CLEAN 2000	is non-flammable does not require special marking does not have an irritating odour is not caustic is physiologically unobjectionable is biologically degradable is registered with the Federal Office for the Environment, Reg.-No. 04860019
-----------------	--

BOLL CLEAN 2000 can be undercooled or overheated during storage but remains fully usable when returned to normal temperature.

### MESH CONTAMINATED WITH HEAVY OIL:

Elements contaminated with heavy oil must be soaked in a standard commercial solvent. After soaking the elements are cleaned in the BOLL & KIRCH Type 5.04 Cleaning Device using BOLL CLEAN 2000 and high pressure pump.

### INSTRUCTIONS FOR USE:

Use of BOLL CLEAN 2000 is not restricted to a particular method of cleaning. Depending on the operating conditions, BOLL CLEAN 2000 can be used in a dip bath, in a spraying plant, in steam jetting or in manual application using a cloth, brush or sponge. It can be used warm or cold. BOLL CLEAN 2000 is miscible with water - even seawater. Concentration for mesh cleaning: 1 : 2,5

Temperature: up to a maximum of 60 °C

The concentration depends on the type and thickness of the adhesive substance to be removed. When used in concentration below 1:30 rinsing is usually not required. No visible film remains on the surface.

### 13. Manual Cleaning of the Candle Elements

Observe drawing Z40357



Before the filter element assembly (5) with the candle elements (6) is dismantled, the automatic filter must be drained by automatic back-flushing. "Manual" activation on the switch box.

The filter elements are to be dismantled as described below:

- 13.1 Remove the cheese head screws (76). Then pull the entire upper assembly - cover (3), limit switch (128), drive attachment (4) with pneumatic swivel drive (119) including solenoid valve (121) - up and out of the housing (2).
- 13.2 Now pull the filter element assembly (5) with the candle elements (6) up and out of the housing (2).
- 13.3 Then soak the filter element assembly, with the candle element openings facing down, in a suitable tank filled with solvent. Detached contaminants can then sink downwards out of the candle.
- 13.4 The soaking time and relevant solvents are:
  - a) In the cold cleaner BOLL CLEAN 2000, the maximum soaking time is 24 hours.
  - b) In Filterclean (Vecom), the maximum soaking time is 12 hours.
  - c) In Reiniger B85 (Vecom), the maximum soaking time is 12 hours.
  - d) In gas oil, the maximum soaking time is 48 hours.
- 13.5 After soaking, remove the entire filter element assembly from the tank and place it on a suitable stand (e.g. perforated sheet metal) with the candle element openings facing down and allow the solvent to drain.

- 13.6 Now, with the cleaning gun supplied, blow compressed air through the candles from the inside to the outside.
- 13.7 After this procedure the entire filter element assembly must be immersed again in fresh cleaner, with the candle element openings facing down, and rinsed through with an up and down motion.



This washing procedure described in Section 13.5 may only be carried out in a separate tank using clean solvent. The solvent can then be used again for the next soaking operation.

- 13.8 Allow the filter element assembly to drain again and dry it by blowing compressed air through it from the inside to the outside.  
The manual cleaning procedure described here has produced adequate results (approx. 60% clean) in similar applications.
- 13.9 Almost 100% manual cleaning is only possible, in our experience, using the type 5.04 high-pressure cleaning unit with BOLL CLEAN 2000.  
See the separate description "Filter Cleaning Unit Type 5.04".



#### 14. Maintenance instructions ( bypass filter )



***Take the bypass filter out of operation before carrying out maintenance work on it!***

To remove the screen insert, proceed as follows:

1. Slacken venting screw (item 332) of the cover retaining arrangement and in this way check that the filter housing is not pressurized.
2. Unscrew the venting screw until the cover panel (item 335) over the concealed cover screws (item 323) can be swivelled.
3. Remove cover (item 306) after slackening the cover screws and pull screen insert out of the filter housing.
4. Clean screen insert with suitable solvents (see KV349) and then blow through with compressed air from the inside to the outside.
5. Check seals and replace any damaged seals.
6. Assemble filter in the reverse order.



DOCUMENTATION PARTS LIST

Date 17.12.04  
Page 1

Document 0638576  
Description automatic filter  
6.62 Gr.04 DN40  
  
Material EN-JS1030  
EN-GJS-400-15  
EN 1563  
Assembly Z100840  
Dimension drawing Z100826

Filter room:  
max. allowable pressure : 16 bar  
max. allowable temperature : 160°C  
Heating room:  
max. allowable pressure: 14 bar  
max. allowable temperature : 200°C  
Test pressure : 2 x Calculation pressure

Item	ID no.	Description	Qty	Unit
00001	6139924	housing lower part	1	pcs.
00002	6139920	housing	1	pcs.
00003	6130313	cover	1	pcs.
00004	5700318	distance piece	1	pcs.
00005	6130333	sieve body	1	pcs.
00006	9905005	star-pleated element according to orde	3	pcs.
00007	5906594	cover	1	pcs.
00007	5218298	nozzle	1	pcs.
00007	6712641	bow	1	pcs.
00007	2000266	slotted cheese head screw	2	pcs.
00008	2610023	float	1	pcs.
00008	2611123	pin	1	pcs.
00008	3530032	threaded pipe fitting	1	pcs.
00009	2708947	deep groove ball bearing	1	pcs.
00010	5000292	bushing	1	pcs.
00011	5130338	cover disc	1	pcs.
00011	2300374	bow	1	pcs.
00011	2300601	quick fixing device	1	pcs.
00015	6100317	carrier	1	pcs.
00016	5100341	control disc	1	pcs.
00017	2706240	freewheel	1	pcs.
00018	2206988	supporting disc	1	pcs.
00019	5004718	drive shaft	1	pcs.
00020	2206959	locking ring	1	pcs.
00021	2201003	locking ring	1	pcs.
00026	6130344	air reservoir	1	pcs.
00027	6139926	housing mud drain	1	pcs.
00028	5001563	valve face	1	pcs.
00029	5000353	valve ram	1	pcs.
00030	5100355	piston screw	1	pcs.
00031	5100356	damper bushing	1	pcs.
00035	5702156	square counter flange	1	pcs.
00036	2800063	square counter flange	2	pcs.
00037	5004049	flange heating	1	pcs.
00043	2401000	feather key	1	pcs.

.....  
DOCUMENTATION PARTS LIST

Date 17.12.04  
Page 2

0638576 automatic filter  
6.62 Gr.04 DN40

Item	ID no.	Description	Qty	Unit
00044	2300016	Spring Type Straight Pin	1	pcs.
00045	2300016	Spring Type Straight Pin	1	pcs.
00046	2310039	Spring Type Straight Pin	1	pcs.
00050	3030180	o-ring	1	pcs.
00051	3030729	o-ring	1	pcs.
00052	3030180	o-ring	1	pcs.
00053	3090218	o-ring	2	pcs.
00054	3048235	o-ring	1	pcs.
00055	3098361	o-ring	1	pcs.
00056	3030063	o-ring	1	pcs.
00057	3040158	o-ring	1	pcs.
00059	3031077	o-ring	1	pcs.
00060	3098361	o-ring	1	pcs.
00061	3094563	o-ring	3	pcs.
00062	3031047	o-ring	1	pcs.
00063	3038188	o-ring	1	pcs.
00064	2785451	seal piston	1	pcs.
00065	3132369	o-ring	1	pcs.
00066	3384063	flat gasket heating	1	pcs.
00067	3380001	high pressure gasket	2	pcs.
00068	3270008	gasket	1	pcs.
00069	3270004	gasket	1	pcs.
00074	2100011	hexagon nut	6	pcs.
00075	2000482	stud bolt	6	pcs.
00076	2000155	hexagon socket head cap screw	6	pcs.
00077	2000131	hexagon socket head cap screw	4	pcs.
00078	2000122	hexagon socket head cap screw	1	pcs.
00079	2000153	hexagon socket head cap screw	3	pcs.
00081	2000122	hexagon socket head cap screw	4	pcs.
00082	2100006	hexagon nut	2	pcs.
00083	2000143	hexagon socket head cap screw	4	pcs.
00084	2000144	hexagon socket head cap screw	4	pcs.
00085	2000147	hexagon socket head cap screw	4	pcs.
00086	2000035	hexagon screw	8	pcs.
00087	2100006	hexagon nut	8	pcs.
00088	2000001	stud bolt	6	pcs.
00089	2000122	hexagon socket head cap screw	2	pcs.
00090	2002155	hexagon socket head cap screw	2	pcs.
00091	2002155	hexagon socket head cap screw	2	pcs.
00092	2000967	hexagon socket head cap screw	2	pcs.
00093	2000122	hexagon socket head cap screw	4	pcs.
00094	2000261	slotted cheese head screw	2	pcs.
00096	2100004	hexagon nut	6	pcs.
00097	2000004	stud bolt	2	pcs.
00098	2209799	spring ring	4	pcs.
00099	2200235	spring ring	4	pcs.
00100	2201574	spring ring	1	pcs.
00101	2200007	disc	1	pcs.
00102	2209021	disc	1	pcs.
00104	2000205	screwed sealing plug	2	pcs.
00105	2001772	screwed sealing plug	1	pcs.
00106	2000189	screwed sealing plug	1	pcs.

DOCUMENTATION PARTS LIST

Date 17.12.04  
Page 3

0638576 automatic filter  
6.62 Gr.04 DN40

Item	ID no.	Description	Qty	Unit
00107	2500024	screwing	4	pcs.
00108	2500025	screwing	6	pcs.
00109	2505496	screwing	1	pcs.
00110	2564886	removeable double nibble	2	pcs.
00112	2560356	angle ball valve	1	pcs.
00113	2560063	angle ball valve	2	pcs.
00115	0600642	tubing set	1	pcs.
00116	2500025	screwing	1	pcs.
00119	4503501	double piston slewing gear	1	pcs.
00120	9902572	differential pressure indicator acc. t	1	pcs.
00121	4105912	connector plug	1	pcs.
00121	2656655	solenoid valve	1	pcs.
00121	4206553	coil	1	pcs.
00122	2656655	solenoid valve	1	pcs.
00122	4206553	coil	1	pcs.
00122	4105912	connector plug	1	pcs.
00123	2650017	high pressure control device	1	pcs.
00124	2608775	non return valve	1	pcs.
00125	2614171	sound absorber	2	pcs.
00126	2600044	pressure gauge	1	pcs.
00127	2660005	safety valve	1	pcs.
00128	4200062	limit switch	1	pcs.
00129	4160351	angle cable screwing	1	pcs.
00129	4160349	reducing ring	1	pcs.
00130	5950197	connection box	1	pcs.
00131	8450198	cover for connection box	1	pcs.
00132	3380199	flat gasket	1	pcs.
00134	4105616	clamp	10	pcs.
00134	4105617	clamp	4	pcs.
00134	4100015	distance plate	3	pcs.
00136	2000258	slotted cheese head screw	2	pcs.
00137	4105801	mounting rail	1	pcs.
00138	4100085	cable gland	6	pcs.
00138	4100086	cable gland	1	pcs.
00140	9401690	type plate	1	pcs.
00141	9407569	label: "in / out"	1	pcs.
00141	9400997	label: "on / off"	1	pcs.
00141	9407396	label: "mud drain"	1	pcs.
00141	9402898	label	1	pcs.
00141	9403614	label: "compressed air connection"	1	pcs.
00145	6705032	key for unscrewing the filter element	1	pcs.
00150	4300000	control box according to order	1	pcs.
00160	5065912	flushing bush	1	pcs.
00162	5003207	thrust piece	1	pcs.
00165	2708946	deep groove ball bearing	1	pcs.
00167	3030060	o-ring	1	pcs.
00168	2310110	shaft spring	1	pcs.
00169	2000123	hexagon socket head cap screw	1	pcs.

Überarbeitet am : 08.12.04

Überarbeitet von : Bogda

Z45550  
TYP4.36.2  
17.03.03

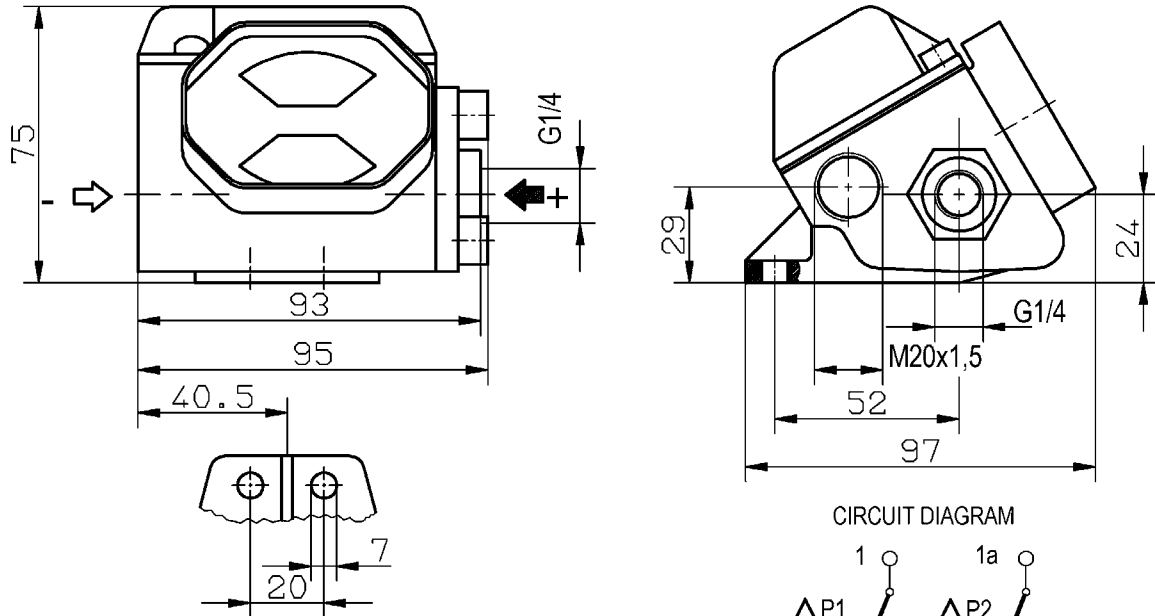

SPECIFICATION:  
PROTECTION CLASS: IP 65

ELECTR. DATA:	SWITCHING VOLTAGE	V $\approx$ MAX.=	250	220
	FREQUENCY	HZ MAX.=	0-60	0-60
	SWITCHING CURRENT	A MAX.=	1	0.8
	MAKING AND/OR BREAKING CAPACITY	WVA MAX.=	60/60	40/60
MATERIAL :	GD - ALUMINIUM			
RATING :	MAX. PRESSURE 100 BAR			
	MAX. TEMPERATURE 150°C			

RANGES OF PRESSURE DIFFERENTIAL: DELTA P =	0 - 0.5 BAR	} TO BE SPECIFIED WHEN ORDERING
	0 - 0.8 BAR	
	0 - 1.2 BAR	
	0 - 2.0 BAR	
	0 - 3.0 BAR	

DESCRIPTION:

THE PURPOSE OF THIS DEVICE IS THE MEASUREMENT, AND VISUAL INDICATION OF THE DIFFERENCE IN PRESSURE BETWEEN TWO POINTS, AND THE ESTABLISHMENT OF AN ELECTRICAL CONTACT WHEN THE PRESSURE DIFFERENTIAL ATTAINS A SPECIFIED FIGURE.

METHOD OF OPERATION:

A PLUNGER SEALED BY A DIAPHRAGM SEPARATES THE SPACE UNDER PRESSURE INTO TWO CHAMBERS. A PRE-LOADED SPRING CAUSES THE PLUNGER TO TAKE UP ITS ZERO POSITION WHEN THE PRESSURE DIFFERENCE DELTA P IS ZERO. AS THE PRESSURE DIFFERENCE INCREASES (DELTA P > 0), THE PLUNGER IS FORCED TO MOVE AGAINST THE SPRING. AT THE SAME TIME, AN INDICATOR DISC IS MOVED MAGNETICALLY, AND THEREFORE VIRTUALLY WITHOUT FRICTION, AND THE TWO REED CONTACTS ARE ACTUATED.

THE RED SEGMENT OF THE INDICATOR DISC IS VISIBLE OVER A PRESSURE RANGE EQUAL TO APROX.50-100% DELTA P. THE FIRST REED CONTACT IS ACTUATED AT 75% DELTA P1, AND THE SECOND AT 100% DELTA P2.

DIFFERENTIAL PRESSURE CONTACT INDICATOR TYPE 4.36.2

Z21434  
TYP4.36.2+4.46.2  
11.02.94

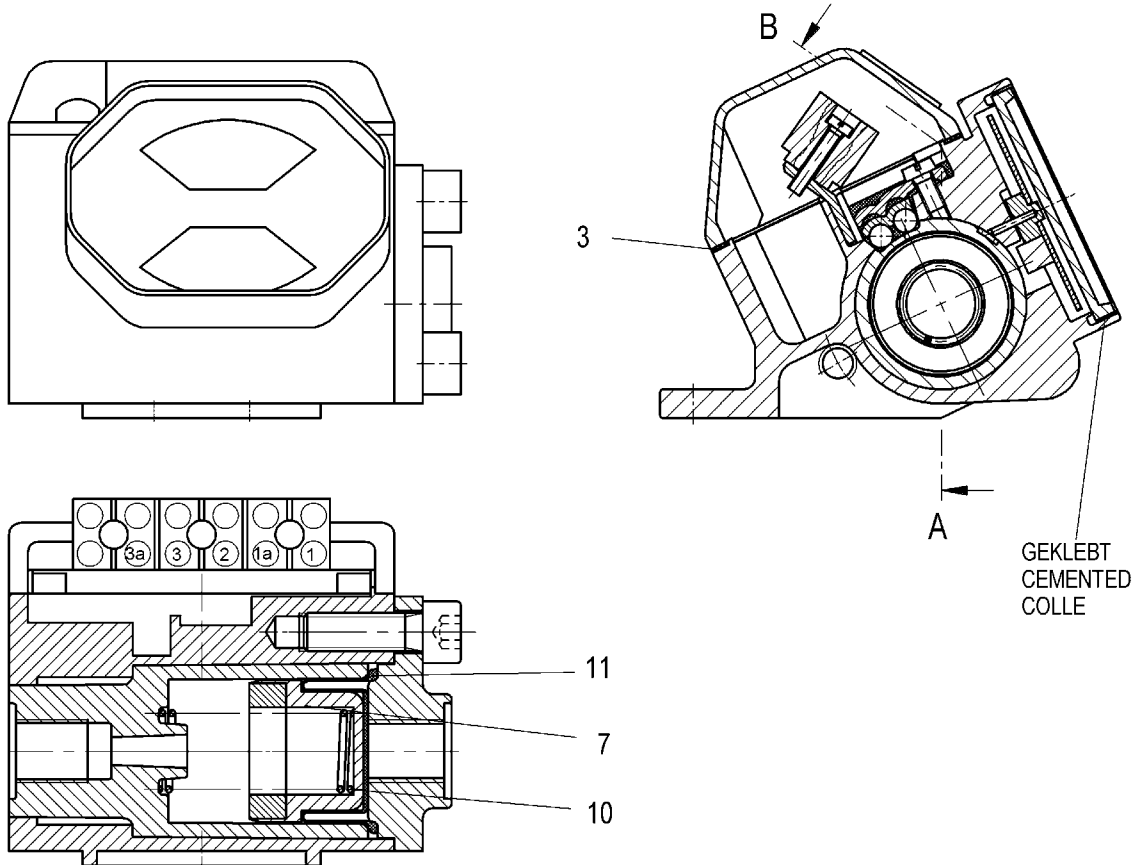

A - B

BEI BESTELLUNG ANGEBEN  
TO BE MENTIONED IN CASE OF ORDER  
A MENTIONNER LORS DE LA COMMANDE

AUFTR.NR.:  
ORDER NO.  
NO DE COMMANDE

TYP 4.36.2

11	ROLLMEMBRAN	DIAPHRAGM	DIAPHRAGME	
10	FEDER	SPRING	RESSORT	
7	KOLBEN	PISTON	PISTON	
3	DICHTUNG	GASKET	JOINT	
POS.NR.	BEZEICHNUNG	DESIGNATION	DESIGNATION	

SPARE PARTS  
DRAWING

ERSATZTEILZEICHNUNG  
ZUM TYP 4.36.2 UND 4.46.2

PLAN DES PIECES  
DE RECHANGE

Bei Service- und Ersatzteilbedarf wenden Sie sich bitte an das Stammhaus oder an unsere Niederlassungen, Vertretungen oder Service-Stellen.  
If you need service or spares for our products please contact our head office or our branch-offices, agencies or service-stations.



### Europa / Europe

#### Deutschland/Germany Zentrale / Headquarters

① ② ③ BOLL & KIRCH Filterbau GmbH  
Postfach 1420, 50143 Kerpen  
Siemensstr. 10-14, D-50170 Kerpen  
Tel.: +49/2273/562-0  
Fax.: +49/2273/562-223  
E-Mail: info@bollfilter.de

① ③ BOLL & KIRCH Filterbau GmbH  
Geschäftsstelle Nord  
An der Strusbek 34  
22926 D-Ahrensburg  
Tel.: +49/4102/4740-0  
Fax.: +49/4102/4740-22  
E-Mail: ursula.bauer@bollfilter.de

① IVG Pumpen- und Filtrationstechnik Gera  
Prehls 13 A  
D-07552 Gera  
Tel.: +49/365/42 00 07 4  
Fax.: +49/365/42 00 07 5  
E-Mail: ivg-neubert@superkabel.de

① BOLL & KIRCH Filterbau GmbH  
Geschäftsstelle Süd  
Rangaustraße 7 a  
D-91639 Wolframs-Eschenbach  
Tel.: +49/9875/884 (Herr Henkelmann)  
Tel.: +49/9875/971865 (Herr Pirkl)  
Fax.: +49/9875/885  
E-Mail: norbert.henkelmann@bollfilter.de

① ② ③ Austria/Czech.Rep./  
Rep. of Slovakia/Slovenia  
Schmachtl KG  
Pummererstraße 36  
A - 4021 Linz  
Tel.: +43/732/76 46 0  
Fax.: +43/732/78 50 36  
E-Mail: g.oebler@schmachtl.at

① ② ③ Belgium/Luxembourg  
AUXIMECA S.A.  
Glasstraat 19  
B - 2170 Merksem  
Tel.: +32/3/64 66 180  
Fax.: +32/3/64 69 398  
E-mail: info@auximeca.be

① Croatia  
Marine Trade d.o.o.  
Vladimira Nazora 6  
HR-47000 Karlovac, Kroatien  
Tel.: +385-47-61 13 65  
Fax.: +385-47-61 42 81  
E-Mail: marine-trade@ka.htnet.hr

① Cyprus  
M.I.E. Services Ltd.  
The Hawk Building  
124 Gladstonos Street  
CY-3032 Limassol  
Tel.: +357/25889999  
Fax.: +357/25345639  
E-mail: info@mieserv.cy.net

① ② ③ Denmark/Sweden/Norway/Iceland  
Finland/Lithuania/Latvia/Estonia  
BOLLFILTER Nordic  
Skovlytoften 26  
DK - 2840 Holte  
Tel.: +45/ 45/ 42 12 00  
Fax.: +45/ 45/ 42 12 99  
E-mail: info@bollfilter.dk

① ② ③ Greece / Bulgaria  
FILTERKON  
8, Mitsaion Str.  
GR - 117 42 Athen  
Tel.: +30/210/9217671  
Fax.: +30/210/9242242  
E-Mail: filterko@otenet.gr

① ② Italy  
DeCoSta S.R.L.  
Via Bicetti de Buttinoni, 12  
I-20156 Milano  
Tel.: +39-02-38 00 52 83  
Fax.: +39-02-38 00 36 31  
E-Mail: sales@decosta.it

① ② ③ Netherlands  
Lubrafil B.V.  
Aalborg 2  
NL - 2993 LP Barendrecht  
Tel.: +31/180/556255  
Fax.: +31/180/556265  
E-mail: lubrafil@lubrafil.nl

① Russia / Ukraine / Belorussia  
Dr. Alexej Simakov  
P.O. Box 133  
RUS - 198262 St. Petersburg  
Tel. + Fax.: +7/812/7560747  
E-Mail: simakov@rol.ru



Verkaufsbüro  
Agency



Lager  
Stockist



Service  
Service





**1 2 3 Spain/Portugal**  
 Bollfilter España S.L.  
 Zona Cami Ral  
 Paseo del Ferrocarril, 339 3-2  
 E - 08860 Castelldefels  
 Tel.: +34- 93-634 26 80  
 Fax.: +34-93-665 22 79  
 E-mail: carlos.martinez@bollfilter.es

**1 2 Switzerland/Liechtenstein/Poland**  
 Equipement Industriel Genève S.A.  
 120 Route de Frontenex  
 CH - 1208 Genève  
 Tel.: +41/22/73 59 50 0  
 Fax.: +41/22/78 66 17 1  
 E-Mail: info@eig-sa.ch

**1 Turkey**  
 Ares Ltd.  
 DES Sanayi Sitesi  
 117.Sokak C24 Blok  
 81260 Y.Dudullu / Istanbul  
 Tel: + 90 (0) 216 4996252 Pbx  
 Fax: + 90 (0) 216 4996276  
 E-Mail: burak.pabuccoglu@aresmakina.com

**1 2 3 U.K. and Ireland**  
 BOLLFILTER UK LTD  
 Commerce Park, Whitehall Road  
 GB - Colchester, Essex C02 8HX  
 Tel.: +44-120679 22 34  
 Fax.: +44-1206-79 30 04  
 E-Mail: john@bollfilteruk.co.uk

 **Amerika / America**  
**1 2 3 BOLL FILTER CORPORATION**  
 USA - Plymouth, MI 48170  
 Tel.: +1 -734-451-4680  
 Fax.: +1 -734-451-4681  
 E-Mail: latorre@bollfilterusa.com

**2 3 Motor-Services Hugo Stamp, Inc.**  
 USA - Ft. Lauderdale, Florida 33315  
 Tel.: +1 (954) 763-3660  
 Fax.: +1 (954) 763-2872

**1 Brazil**  
 Petersen Matex Ltd.  
 BR - 20093-900-Rio de Janeiro  
 Tel.: +55/21/2211-5050  
 Fax.: +55/21/2518-2220  
 E-Mail: Max.Herrmann@pml.com.br

 **Asien / Asia**  
**1 Hongkong/P.R. of China/Macao**  
 BVI Marine Systems Ltd.  
 HK - Hong Kong SAR  
 Tel.: +852-3181 7830  
 Fax.: +852-2541 2171  
 E-mail: info@bvi-marine.com.hk

**1 India**  
 A.K. Dutta  
 IND - Navi Mumbai 400614  
 Tel.: +91/222/75 60 147  
 Fax.: +91/222/75 60 146  
 E-mail: akdutta123@vsnl.net

**1 2 3 Japan**  
 Bollfilter Japan Ltd.  
 Japan / Kobe, 651-0085  
 Tel.: +81/78/242 8550  
 Fax.: +81/78/242 8515  
 E-mail: info@bollfilter.jp

**1 2 3 Singapore / Malaysia / Indonesia**  
 MNM Corporation Pte. Ltd.  
 SGP - Singapore 629021  
 Tel.: +65/6/86 14 22 2  
 Fax.: +65/6/86 24 22 2  
 E-Mail: mnmcorp@singnet.com.sg

**1 2 3 South Korea**  
 Blohm & Voss (Korea) Ltd.  
 ROK - Pusan / Korea  
 Tel.: +82/51/74 05 70 1  
 Fax.: +82/51/74 05 70 4  
 E-Mail: bvkorea@kornet.net

**1 2 United Arabian Emirates Middle East**  
 M/S Safe Technical Supply Co. L.L.C.  
 P.O. Box 4832  
 Dubai  
 Tel.: +971-4-3243240  
 Fax.: +971-4-3243786  
 E-Mail: safetec@emirates.net.ae

 **Australien / Australia**  
**1 2 3 Peacock & Smith Pty Ltd.**  
 AUS - Kensington Vic. 3031  
 Tel.: +61/39/37 64 49 9  
 Fax.: +61/39/37 62 16 5  
 E-Mail: filters@peacocks-aus.com

 **Afrika / Africa South Africa**  
**1 2 Afrifil Industrial Filters (Pty) Ltd.**  
 ZA - Isando, 1600  
 Tel.: +27/11/452 5444  
 Fax.: +27/11/609 9535  
 E-Mail: sales@afrifil.co.za